



**S.N.D.M.O**

au service de la technologie  
France +info 02 41 96 97 97

**HEIDENHAIN**



Preliminary Product  
Information

## **LIP 281**

Exposed Linear Encoder

# LIP 281 Series

Incremental linear encoders for very high accuracy and high position stability

- For measuring steps of 0.001  $\mu\text{m}$  (1 nm) and smaller
- For high traversing speeds and large measuring lengths

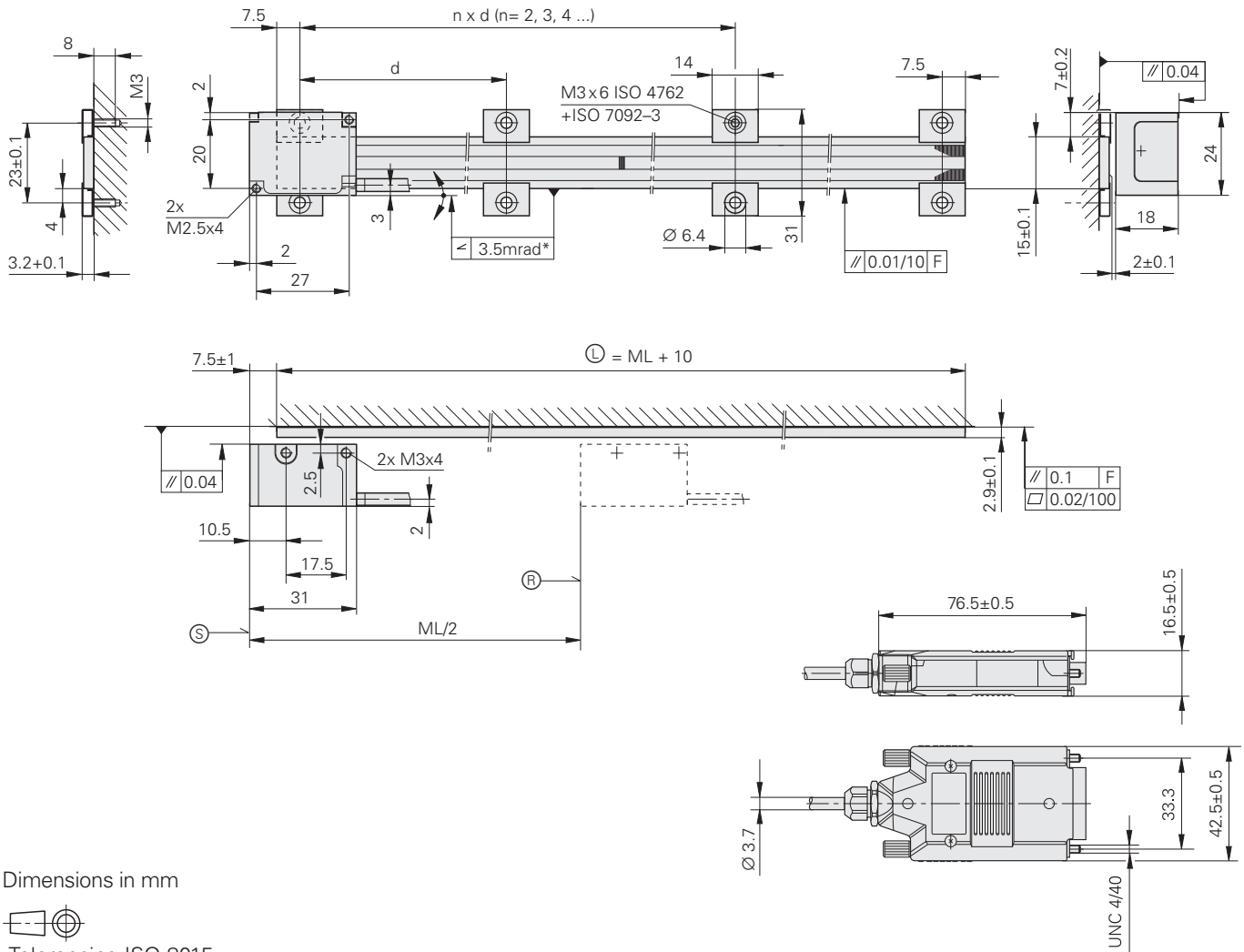

Dimensions in mm



Tolerancing ISO 8015  
ISO 2768 - m H  
< 6 mm:  $\pm 0.2$  mm

Required pairs of fixing clamps:  
2 for  $ML \leq 70$   
3 for  $ML \leq 120$   
One additional pair for each 100 mm of measuring length

- F = Machine guideway
- Ⓡ = Reference mark position
- Ⓢ = Scale length
- Ⓣ = Beginning of measuring length (ML)
- \* = Max. change during operation
- d = With more than two pairs of fixing clamps, distances must be equidistant



Specifications	LIP 281
<b>Measuring standard</b> Coefficient of linear expansion	OPTODUR phase grating on Zerodur® glass ceramic $\alpha_{\text{therm}} \approx (0 \pm 0.1) \times 10^{-6} \text{ K}^{-1}$
<b>Accuracy grade</b>	$\pm 3 \mu\text{m}$ (higher accuracy grades available on request)
<b>Measuring length ML*</b> in mm	70 120 170 220 270 320 370 420 470 520 570 620 670 720 770 820 870 920 970 1020 (Larger measuring lengths upon request)
Reference marks <i>LIP 281 R</i> <i>LIP 281 C</i>	One at midpoint of measuring length Distance-coded (upon request)
<b>Incremental signals</b>	$\sim 1 \text{ V}_{\text{PP}}^{2)}$
Grating period	2.048 $\mu\text{m}$
Signal period	0.512 $\mu\text{m}$ (512 nm)
Cutoff frequency -3 dB	$\geq 6000 \text{ kHz}$ (laser class 3B)
<b>Traversing speed</b>	$\leq 180 \text{ m/min}$ (laser class 3B)
<b>Power supply</b>	5 V $\pm 5 \%$
<b>Electrical connection</b>	Cable 0.5 m with D-sub connector (15-pin), interface electronics integrated in the connector
<b>Cable length</b> <sup>1)</sup>	$\leq 30 \text{ m}$
<b>Vibration</b> 55 to 2000 Hz <b>Shock</b> 11 ms	$\leq 200 \text{ m/s}^2$ (IEC 60068-2-6) $\leq 400 \text{ m/s}^2$ (IEC 60068-2-27)
<b>Operating temperature</b>	0 °C to 50 °C
<b>Storage temperature</b>	-20 °C to 70 °C (in the packaging)
<b>Weight</b> Scanning head Connector Scale Connecting cable	59 g 140 g 0.11 g/mm overall length 22 g/m

\* Please select when ordering



<sup>1)</sup> With HEIDENHAIN cable

<sup>2)</sup> Additional interfaces via external interface electronics with integrated interpolation. Please request more information about:

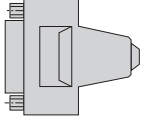

- TTL with APE 371 (the traversing speed depends on the interpolation)
- EnDat 2.2 with EIB 392 (traversing speed  $\leq 12.2 \text{ m/min}$ ; 16384-fold subdivision)
- Fanuc Serial Interface with EIB 392F (traversing speed  $\leq 12.2 \text{ m/min}$ ; 16384-fold subdivision)
- Mitsubishi High Speed Serial Interface with EIB 392M (traversing speed  $\leq 12.2 \text{ m/min}$ ; 16384-fold subdivision)

# Electrical Connection

<b>Mating element on connecting cable to connector on encoder cable</b> 		<b>D-sub connector (female), 15-pin</b> 	
For connecting cable	$\varnothing$ 8 mm $\varnothing$ 6 mm	315650-14	

<b>PUR connecting cable <math>\varnothing</math> 8 mm</b> $[4(2 \times 0.14 \text{ mm}^2) + (4 \times 0.5 \text{ mm}^2) + 2 \times (2 \times 0.14 \text{ mm}^2)]$ Shield on housing		
<b>PUR connecting cable <math>\varnothing</math> 6 mm</b> $[6(2 \times \text{AWG28}) + (4 \times 0.14 \text{ mm}^2)]$	$\varnothing$ 8 mm	$\varnothing$ 6 mm <sup>1)</sup>
<b>Complete</b> with D-sub connector (female) and connector (male) 	335074-xx	355186-xx
<b>With one</b> D-sub connector (female) 	332433-xx	355209-xx
<b>Cable without connectors</b> 	244957-01	291639-01

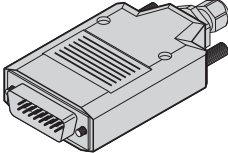
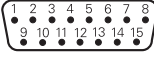
<sup>1)</sup> Cable length for  $\varnothing$  6 mm max. 9 m

<b>15-pin D-sub connector with integrated interface electronics</b>   													
	Power supply				Incremental signals						Other signals		
	4	12	2	10	1	9	3	11	14	7	/	/	8/13/15
	Up	Sensor 5V	0V	Sensor 0V	A+	A-	B+	B-	R+	R-	Vacant	Vacant	Vacant
	Brown/ Green	Blue	White/ Green	White	Brown	Green	Gray	Pink	Red	Black	Violet	Yellow	/

**Shield** on housing; **Up** = Power supply voltage

**Sensor:** The sensor line is connected internally with the corresponding power line

## HEIDENHAIN

**DR. JOHANNES HEIDENHAIN GmbH**

Dr.-Johannes-Heidenhain-Straße 5

83301 Traunreut, Germany

☎ +49 (8669) 31-0

FAX +49 (8669) 5061

E-mail: info@heidenhain.de

www.heidenhain.de

### For more information

- Exposed Linear Encoders brochure
- EIB 392 Product Information
- APE 371 Product Information